

DENSO PRODUCTS AND SERVICES AMERICAS, INC.

C-V2X Roadside Unit (RSU)

Advanced Technology Roadside Unit

RSU-5940 PCBA



RSU Platform

The RSU-5940 is a V2X Printed Circuit Board Assembly (PCBA) designed for enabling RSU functionality in Traffic Infrastructure deployment in North America. Our company leveraged over a decade of research and development expertise working with relevant standards bodies, government research organizations, and OEMs to develop a platform capable of meeting anticipated minimum performance requirements and supporting initial V2X use cases for day 1 deployment and beyond.

- PCB Assembly form factor designed for integration into rugged RSU enclosures
- Dynamic Signage
- Traffic Signal Controllers
- Other Traffic Infrastructure
- Automotive grade components
- Adaptable to various business models
- PCB, Full Kit and different system integrators

Quality & Stability

- Tier 1 supplier of OEM safety and communication products
- 72 Years of success in the automotive market and will be able to support long term

Features

Support latest versions of:

- NTCIP 1218 v01.38
- NEMA TS 10 v25
- CTI 4001 v01.00 and CTI 4501 v01.00
- Remote RSU configuration management and diagnostic features
- Antenna fault detection
- Antenna diversity: LTE-V2X: RX & TX diversity

Applications

- V2X application suite
- Signal Phase and Timing / MAP
- Freight/Transit Signal Priority (FSP/TSP)
- Emergency Vehicle Preemption (EVP)
- Traveler Information Messages (TIM)
- Curve Speed Warning
- Speed Compliance / Work Zone
- Oversize Vehicle Compliance
- Red Light Violation Warning
- Emergency Vehicle Warning
- Any numerous other applications

Security

- Developed in compliance with ISO 21434 automotive software cyber security standard
- V2X Hardware Security module (HSM)
- NIST/Brain pool ECC up to 512b
- HSM storage > 10k keys, 15-year retention
- FIPS 140-2 Level 3 / EAL6+

Integration

- Our RSU integrates well with intersections using camera and radars to detect VRUs and can issue real-time alerts to drivers

Hardware Architecture

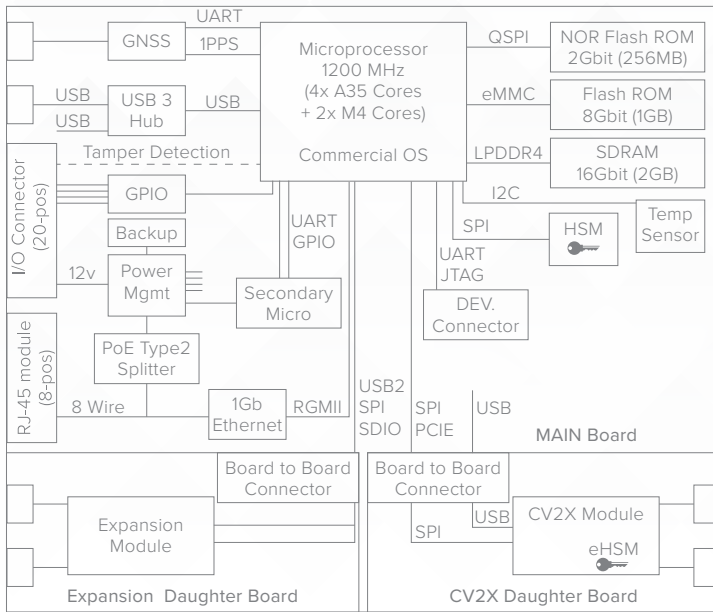

Code Features

- U.S. (IEEE, SAE) protocols
- V2X Facilities Software (SAE protocols)
- V2X Services API (GNSS, V2X Radio)
- Quad-core ARM A35 @ 1.2GHz + M4 (~9000DMIPS)
- 2GB LPDDR4 SDRAM
- 256MB QSPI NOR flash
- 8GB eMMC mass storage
- LTE-V2X R14/15 radio
- GNSS for position and timing
- USB 3.0 (Type-C)
- USB 2.0 Debug (microB)

Standard Conformance

- IEEE 802.11 – 2012
- IEEE 1609 – 2016
- SAE J2735 – 2016
- SAE J2945/1 – 2016
- SAE J3161 (LTE-V2X)
- NTCIP 1218 v01.38

Frequency Band

- LTE-V2X: 5.9GHz ITS (5895 – 5925 MHz)
- GNSS: L1 C/A, L1OF, B1, B1I, E1/BC, G1

DENSO Products and Services Americas, Inc.
 3900 Via Oro Avenue
 Long Beach, CA 90810
 Ph: +310-834-6352
<https://www.denso.com/us-ca/en/about-us/company-information/us/dpam/>

RSU-5940

Software Architecture

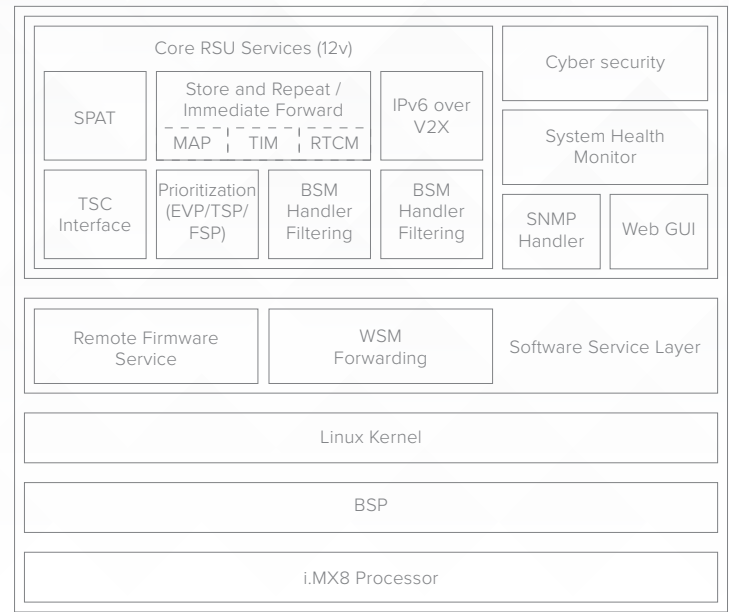

Specifications

Bandwidth

- LTE-V2X: 20MHz, IEEE Ch. 183

Antenna Diversity

- LTE-V2X: RX Diversity (MRC), TX Diversity (CDD)

Max Transmit Power

- LTE-V2X: Up to +23 dBm

Receiver Sensitivity (single input)

- LTE-V2X target: -95dBm
- (MCS 11, 367 octets, HARQ)

GNSS

- 2.0m CEP (up to 10Hz)

V2X Security

- NIST/Brainpool ECC up to 512b
- HSM storage > 10k keys, 15-year retention
- FIPS 140-2 Level 3 / EAL6+

Operating System

- Embedded Linux (5.15.72)

Operating Temperature Range

- -40°C to +85°C (PCBA)
- Intended for RSU integration compliance with ITE CTI 4001

Dimensions

- 140mm x 115mm x 35mm

Power Supply

- 12V ±10% (< 22 Watts)