

DENSO PRODUCTS AND SERVICES AMERICAS, INC.

Dual Mode (DSRC + C-V2X) On Board Unit (OBU)

Advanced Technology On Board Unit

Hercules OBU



OBU Platform

The Hercules OBU is a modular telematics control unit (TCU) designed to support development of advanced vehicle safety and mobility features. Our company has built on the success of the Wireless Safety Unit product line to create a highly capable development platform bringing together the latest short-range and wide-area automotive communication technologies. Automotive grade components ensure reliable operation and our company provides excellent customer support for integration, customization, and testing.

- The Hercules OBU includes C-V2X and DSRC radios to enable V2X performance benchmarking and technology transition strategies, plus LTE & Wi-Fi/Bluetooth.
- Server configurations - OTA software and configuration update, log file upload, and integration with the Security Credential Management System (SCMS).

Quality & Stability

- Tier 1 supplier of OEM safety and communication products.
- 72 Years of success in the automotive market and will be able to support long term.

Security

- Uses the latest generation V2X hardware security module for tamper resistant key storage.
- V2X Hardware Security Module (HSM) (x2)
- 15-year key storage
- FIPS 140-2 Hardware Security Module

Features

- Modular design with plug-in daughter cards
- Supports US (IEEE, SAE) V2X protocols
- V2X Facilities Software (SAE protocols)
- V2X Services API (CAN, GNSS, V2X Radio)
- Quad-core ARM Automotive System On-Chip
- LPDDR4 SDRAM / NOR Flash
- eMMC / SD Card (Bootable)
- GNSS w/ multi-constellation support
- 4G LTE Modem
- 802.11ac Wi-Fi + Bluetooth 4.1 (Future capabilities)
- 2 Wire Ethernet / CANbus (x2)
- USB-C & USB Debug
- HDMI Output / Audio Output

Applications

- V2X application suite
- Comprehensive list of CV applications (V2I, V2V, V2P) ready for customer deployment and integration
- Transit Signal Priority (TSP)
- Emergency Vehicle Preemption (EVP)
- Freight Signal Priority (FSP)
- Pedestrian Collision Warning (PCW)
- Red Light Violation Warning (RLVW)
- Intersection Movement Assist (IMA)
- Emergency Electronic Brake Lights (EEBL)
- Forward Collision Warning (FCW)
- Blind Spot /Lane Change Warning (BSW/LCW)
- Signal Countdown
- Wrong Way Driving

Traveler Information Message (TIM) based alerts:

- Speed Limit Advisory
- Wrong Way Remote Vehicle
- Curve Speed Warning
- Weather Advisories (e.g., freezing rain, thunderstorm, strong winds, hail)
- Road Condition Advisories (e.g., pothole, icy bridge, snow on road)
- Construction Advisories (e.g., road construction, lane closures, work-in-the-median)
- End of Queue Alerts

Hardware Architecture

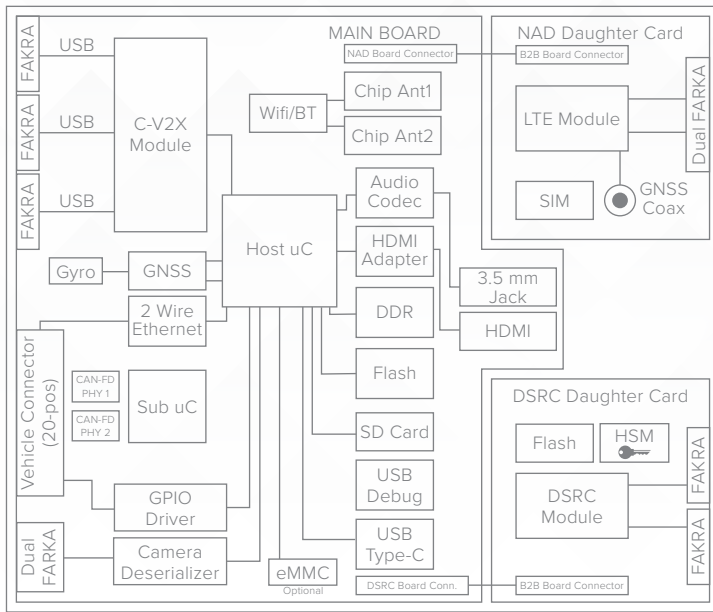

V2X Standard Conformance

- IEEE 1609 - 2016
- SAE J2735 - 2016
- 3GPP R14 (PC5 C-V2X)
- SAE J2945/1 - 2016
- SAE J3161/1 - 2022

Frequency Band

- C-V2X/DSRC: 5.9GHz ITS
- WiFi/BT: 2.4GHz/5GHz
- LTE: 2/4/5/7/12/13/17/29
- GNSS: L1 C/A, L1OF, B1, B1I, E1/BC

Bandwidth

- C-V2X (20 MHz)/DSRC (10 Mhz)

Data Rate

- DSRC: 3-27 Mbps (10MHz)
- WiFi/BT: 300Mbps/24Mbps
- LTE: 600Mbps DL/50Mbps UL

Antenna Diversity

- C-V2X: RX-MRC
- DSRC: TX-CDD, RX-MRC
- WiFi/BT: 2x2 MIMO
- LTE: 2x2 MIMO

DENSO Products and Services Americas, Inc.

3900 Via Oro Avenue
Long Beach, CA 90810

Ph: +310-834-6352

<https://www.denso.com/us-ca/en/about-us/company-information/us/dpam/>

2023 Hercules OBU

Software Architecture

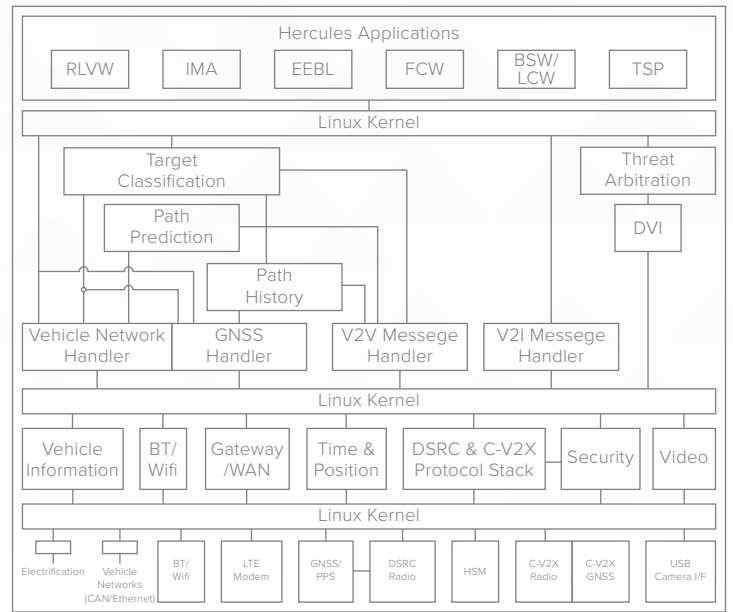

Max Transmit Power

- C-V2X/DSRC: +23dBm
- WiFi: +15dBm
- LTE: +23dBm

Receiver Sensitivity (w/ diversity)

- C-V2X: -96.5 dBm
- DSRC: -95dBm

GNSS

- 2.0m CEP (10Hz)

Operating Temperature Range

- LTE: -30°C to +70°C
- All other systems: -30°C - 85°C

Dimensions

- 160mm x 138mm x 50mm (W x D x H)

Power Supply

- 12V (< 22 Watts)

Vehicle Harness

- Extended vehicle wire harness (~25')

Optional Kit

The Hercules OBU can be supplied as a kit, with the following accessories:

- Integrated V2X and GNSS Antennas with 10' RF Cables
- LTE Antenna with 10' Low Loss Cable
- Vehicle wire harness